

NEWSLETTER

# DIGITAL THREAD FOR PRODUCT SUPPORT

JULY 2021  
NO. 01

## Edito

The LGM Group particularly monitors technical innovations that are likely to have an impact on the organization of support for major multi-sector programmes. The purpose of this newsletter is to provide you with a techni-

cal insight into the digitization of Integrated Logistics Support and the Digital Continuity of Support around the ASD S-Series (S1000D, S2000M, S3000L, S6000T...) as well as to present the expertise of LGM Group in this field.

It will also be an opportunity for you to discover our dedicated Business Line, allowing us to pool internal skills, capitalize on projects and experience, and develop a multi-sector synergy. (For more information: consulter see our [online brochure](#)).

### CONTRACTS

#### MBDA France

LGM is proud to count MBDA France among our new eLSA software users. MBDA France is a major international group that designs and produces weapons systems for each branch of the armed forces (air, land and sea).



#### KONGSBERG Defence & Aerospace



KONGSBERG

LGM Digital, in partnership with the Swedish company Eurostep, deployed our ASD S2000M TEDI solution at Kongsberg Defence & Aerospace in late 2020. The installation and the training were successfully carried out

remotely. A software upgrade is already planned for the third quarter of 2021. This contract should be the first step in a wider deployment of our ASD factory solutions, starting with eLSA!



eurostep

# The SIMMT trusts LGM

In the April newsletter, the **SIMMT** (Structure Intégrée du Maintien en condition opérationnel des Matériels Terrestres [Integrated In-Service Support Structure for Land Equipment]), explains why it **has entrusted the development of its IDM module to LGM:**



“The module’s specifications supplier (LGM) conducted an analysis, which shows that eLSA natively covers a certain number of requirements stated by the user group (consisting of representatives of technical brand expertise departments). Moreover, systems and maintenance engineering is the core business of LGM. As such, the problems encountered by the technical brand experts and, more broadly, those of the SIMMT professions are well known to LGM’s functional managers. This allows them to offer suitable, effective solutions.”

*Lieutenant-colonel Jean-Michel BEROUDIAT  
(SIMMT/SDPS/DSIN/BIQF)  
RCPE modularization*

**Source: MCO-T IS Newsletter - Edition n°23 - April 2021**

## SOFTWARE SOLUTIONS

# ASD Factory: a digital maintenance software suite

Aware of the strategic interest of providing software solutions capable of supporting the new concepts of digital maintenance, the LGM Group has developed a suite of products based explicitly on the ASD S-Series standards. With this, LGM is able to provide our clients with interoperable solutions specified and defined by and for business line experts. These software solutions, aptly named the ASD Factory, covers the entire ASD range, and in particular:

- eLSA to support the **S3000L**,
- TEDI to support the **S2000M**,
- Training Designer to design training courses in line with **S6000T**,
- Cindy a **CMMS compatible with S5000F**, paired with the HUMS solution MOKA.
- Other internal prototypes are under development.

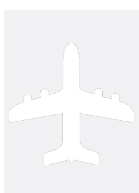

**AIR & COSMOS**, the BtoB aerospace magazine has dedicated an **article to our ASD Factory!** Learn more about our activities and new ASD solutions to optimize the performance of support components.

*(AIR&COSMOS Edition - MCO Feature - Issue n°2724 - March 5, 2021).*

Find the latest news in aeronautics on [air-cosmos.com](http://air-cosmos.com)  
<https://www.lgm.fr/actu/air-cosmos-asd-factory>

# DATA MANAGEMENT: MIDAS



In recent years, since the use of ASD has accelerated in the support system, our clients increasingly encounter a new documentation problem of converting proprietary WORD or XML documentation to S1000D XML documentation. Fort de ce constat, With this in mind, LGM designed MIDAS (an Automated Documentation Migration tool) around the ETL (Extract Transform Load) TALEND, an open source tool specialized in data processing, used by a large worldwide community of specialists and players in Big Data. MIDAS creates an equivalence and after analysis automatically transfers

data between WORD styles (or another format) and structured elements. It has been developed with a modular and hence more easily adaptable architecture, taking the different potential needs of our clients into account with regard to the desired formats (WORD, EXCEL, XML S1000D 2.3/4.0.1/4.1). This tool enhances productivity, guarantees that the data will be preserved in the source version while creating XML output. MIDAS reflects LGM's DNA of combining

our know-how to offer ever more innovative and custom-tailored tool solutions, which combine computer tools and expertise in our core businesses.

*Emilie MICHAUD  
Technical Documentation  
Business Manager  
Technical and Innovation  
department*

We master ASD

Business standards for support

- ASD 5-Series (S1000D, S2000M, S3000L, S4000P, S5000F, S6000T...)
- Historical standards (MIL-STD 1388, DEF STAN 0060...)

Exchange standards

- structured data : XML, PICS...
- transformation methods: ETL (type : TALEND)
- database synchronization

CUSTOMER	Source		Conversion	Target	
	Standard	Format		Standard	Format
1388-2B	S3000L	TRX	→	S3000L	XML
	S1000D	XML		S1000D	2.2 XML
OWNER	S3000L	XML	→	OWNER	XML
	OWNER	W		S1000D	2.3 XML
OWNER	S1000D	2.3 XML	→	S1000D	4.1 XML
	S1000D	XML		S1000D	4.1 XML
OWNER	S1000D	XML	→	S1000D	XML
	S5000F	EXL		S5000F	XML

Examples of conversions already completed for our clients :

# TEDI for Kongsberg



At the beginning of 2021, LGM Digital provided 5 licenses to KONGSBERG of our product for the production and control of supply documentation: TEDI - Tools for the Exchange and Documentation of ITEMS.

KONGSBERG is a Norwegian multi-sector company that supplies high-tech, naval, aerospace and defence equipment. LGM Digital delivered the production version in March after a 3-month test and exchange period.

In this context, the following features have been deployed in TEDI:

- The S1000D v4.0.1 export of the IPD
- Version 4.0 of the ASD S2000M
- S1000D document guidance that allows writing S1000D rules for IPD exports

**TEDI can natively export the supply documentation as S1000D versions 4.0.1 and 4.1, regardless of whether it was produced in versions 2.1, 3.0 or 4.0, while taking the programme requirements into account.**

Indeed, the number of rules varies from one programme to another, between rules that prohibit certain values, data or links between TEIs. There may be as many as 100 rules per programme to apply.

LGM Digital has set up a visual system of blocks that are assembled to create or modify existing rules resulting from LGM Digital's experience in provisioning projects:



Thus, the user assembles the bricks and creates the rules in a dynamic and fluid way. Moreover, a panel is available to visualize the result in XML format. In this example, the user only has to assemble two applicability bricks to create the <applic> tag of the S1000D export.

*Alexandre Ben Hamou  
Software Cellule Manager LGM Digital*

# ASD Moving from LSA (S3000L) to doc (S1000D)



A stated objective of the data model specified by the ASD is **to support the transfer of data from one domain to another**, thus ensuring the consistency of information exchanged as part of the digital continuity of support.

**For a project in the air traffic sector, LGM experimented with this data transfer by creating a gateway between LSA data structured in S3000L and S1000D documentation.**

The objective was to initialize the S1000D documentation database with the project's LSA data, available and structured in S3000L. In addition to guaranteeing consistency between the support data and the documentation, this gateway represents a formidable catalyst for creating and producing documentation modules.

In concrete terms, the advantages are as follows:

- Initialize the identifiers of the document modules using the information entered in the LSAR (identification of the project, the product variant, attachment to the functional tree, function code of maintenance tasks...).
- Automatically initialize the content of the S1000D data modules (DM) with the field values available in the LSAR: the support elements (spares, consumables and ingredients, tools) in the maintenance tasks:
  - the characteristics of the maintenance tasks in the data modules: category and qualification of the required personnel, durations, intervals, maintenance levels
  - the content of 'Safety instructions' DMs from the safety warnings contained in the LSAR and the creation of links from the procedures to these DMs using the existing links of the LSAR.

This initialization saves significant time on a documentation project. However, this project implies constraints or rather assumes certain prerequisites so that the gateway can bring the expected benefits:

- The structuring of tasks and sub-tasks in the LSAR must correspond to the S1000D modularization. At a minimum, an existing maintenance task in the LSAR must correspond to an S1000D data module,

- The structuring of the data in the LSAR must correspond to the S1000D constraints and business rules. For example, a decision must be made whether to attach times, qualifications, spares and tools at task or subtask level,
- The logistic tree and the SNS identification of the data modules must converge towards the same functional breakdown strategy. In other words, it is recommended to attach the S1000D SNS to the point of use in the LSAR because it represents a system element (the BEI identifying a tree element).

In addition to the increased productivity generated by the initialization, evolutions can be more easily managed because evolutions on the LSA side are tracked across revisions of maintenance tasks. This allows the editors to quickly identify which maintenance DMs will have to evolve in terms of version after the input data has been updated.

All of these structural constraints make it necessary that the LSA and documentation teams work hand in hand and agree on a strategy for breaking down and identifying common elements (SNS, information codes, etc.).

This implies that the teams can understand each other and speak the same language, which is not necessarily clear! But in the end, taking up this challenge will both guarantee an overall consistency in the project and represent real teamwork for LGM!

*Céline LEREDDE  
Documentation Engineering business referent*

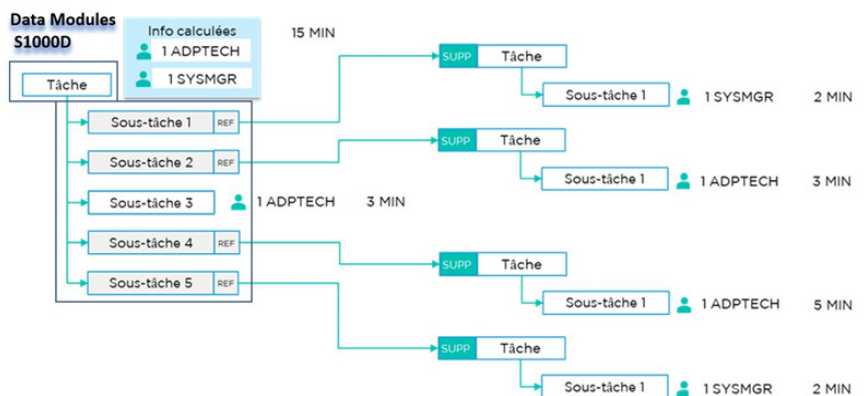

# S5000F: The data from operation



**S5000F is a specification developed to collect data in operation.** You will find in this specification all you need to collect and use the experience feedback to ensure that your system is used and maintained in the right condition. All the domains are covered by the specification, the follow-up of fleet, maintenance, contracts and costs.

This specification contains **two main parts**: the first one is the **data model**, the second one describes **use cases** that can help you define the right data for your application. You must be mindful that the S5000F is, like all specifications of the S-Series, a guide to help you. Accordingly, you have to choose which part of the specification is relevant for your project.

The following figure shows you all the domains that are covered by:

Elements	Product	Safety	Message
Configuration	Fleet	Events and Consequences	Environment and Infrastructure
Maintenance	Operations	Regulatory	Management
Material	Miscellaneous	Information	People and Organizations

First of all, you can create the organization that will operate and maintain the system, define the environment of the different mission, the facilities that will support the system and the different configurations. These domains cover the data from the organization, human resources, environments and infrastructures, products and operations. Then, you will find the data linked to the operation of your system, the duration of the mission, the conditions in which

it operates, the purpose of the mission and whether the mission successfully met its objectives.

Finally, you will find all the necessary data for monitoring your fleet. This domain allows you to keep an eye on the different individual products that are used on your fleet, and collect all the technical facts that occurred during the operations.

The biggest part of the specification is created around the maintenance domain, where you find all you need to maintain and track the maintenance of your fleet from the workorder to the facility planning.

The specification also covers the Health and Usage Monitoring System (HUMS) and allows you to structure data that will be used in a predictive maintenance process.

As you can see, most of the fields linked to the operation of a system are taken into account in the S5000F. However, in order to benefit from the full value of S5000F, it is strongly recommended that it be used in combination with the other specifications of the S-Series and in particular S3000L. In order to simplify the use and exchange of data between the different specifications, the S-Series is based on a data model in several parts. Each specification has its own part, called Unit of Functionality (UoF), and you will find a common data model that collects the different UoFs that are used in two or more specifications. This principle ensures the compatibility between the data that you will collect during operation and the other fields of the support, such as documentation, training or LSA studies.

The second main part of the specification allows you to determine the right usage for your project. It contains some use

cases that can help you define the data set in line with your objectives.

Different domains and applications are described in the specification. You can collect the data to monitor the performance of your system in terms of reliability, availability, maintainability, capability, testability and safety. But you can also collect data in other domains, such as monitoring of costs, software support, configuration management, or warranty analysis.

More than 80 use cases are documented in the specification and the number of applications is high! You will therefore find different ways to optimise the performance of your system in terms of cost or availability.

All use cases are defined with objectives and recommendations for the data set that you have to implement in your project.

The version 2.0 of the S5000F is dated from December 2019 but was not made public until December 2020. This issue of the specification allows for a better compatibility with the other specifications of the S-series and makes the specification easier to use.

In a nutshell, **S5000F is an important specification if you need to track a fleet and define the actual performance of your systems.** To ensure that the specification is implemented on your project to best advantage, it is strongly recommended to use it in combination with the other specifications of the S-Series.

Feel free to ask us if you need more information about this specification!

*Arnaud AUDOUIN  
ILS/ISS Business Manager  
Technical and Innovation  
department*

**On 2 June 2021, LGM participated as a speaker in an event organized by AFNeT: The Standard Days.**

L'AFNeT est depuis 40 ans un réseau d'acteurs expérimentés et reconnus qui se met au service des filières industrielles pour accompagner et développer des projets tels que le Hub collaboratif européen BoostAeroSpace ou les standards PLM internationaux de l'aéronautique et de l'automobile. Les Standard Days qui se tenaient les 1<sup>er</sup> et 2 juin, avaient pour objectif de partager des connaissances et d'échanger autour de la standardisation et des fondements de l'écosystème « Model-Based » dans l'industrie. **LGM was invited by Dassault Aviation to present a session dedicated to MRO/ILS.** Our presentation focused on the new S-Series S6000T specification for training engineering.

The workflow of Training Needs Analysis and Training Design activities:

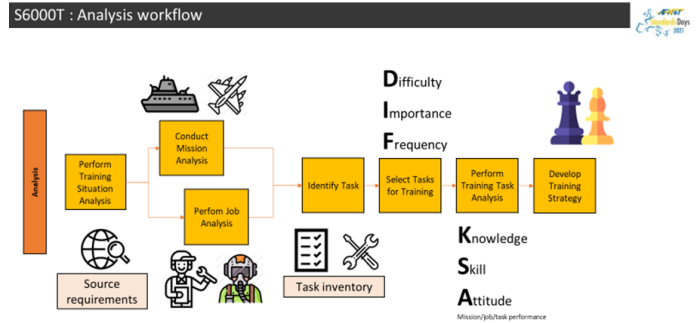

AFNeT Standards Days 2021 : 1 & 2 June 2021 <http://standardsdays.afnet.fr>

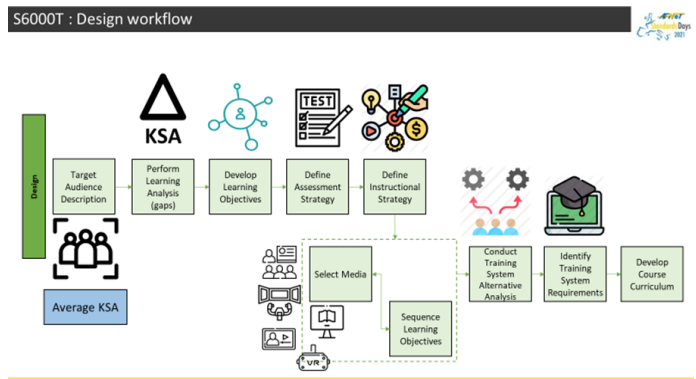

AFNeT Standards Days 2021 : 1 & 2 June 2021 <http://standardsdays.afnet.fr>

the next AFNET MRO 'blockbuster' : 'S6000T - May the Spec be with you'

**Movie title** « Conception and development of a customer adapted Training : through the S6000T 'May the spec be with you' ! »

Released Date : June 2th at 9am

**Main actors** (by apparition order)

- Michel DOMEON / DASSAULT-AVIATION  
"Military Big Data" Product Owner  
ASD PSSG French rep (Product Services Specification Group)
- Gilles BAUDOUX / LGM  
Training Business Manager in Directorate of Technical Innovation  
S6000T Steering Committee member
- Cedric PATERNOSTRE / LGM  
Director of System Engineering and Performances Department
- Paul-Emile NICOLAERS / LGM  
Training Engineer / S6000T Expert



29/05/2021 AFNeT Standards Days 2021 : 1 & 2 June 2021 <http://standardsdays.afnet.fr> 2

Therefore, Dassault and LGM had the opportunity to present the origins and content of S6000T, to place the latter in the overall context of support and to identify the benefits provided by this new specification. The workflow of the Training Needs Analysis and Training Design activities was described in detail. Paul-Emile Nicolaers illustrated the implementation of S6000T through an example built around the use and maintenance of a mountain bike.

'S6000T - May the Spec be with you'

- Ep1 : Introduction on S-series (S6000T relationships)
- Ep2 : - Background of training specs  
- The Training ADDIE model → Analysis / Design/ Develop / Implement / Evaluate  
- Focus on S6000T Framework and Content for Analysis & Design workflows including last issue updates
- Ep3 : Use case in practice
- Ep4 : Synthesis and benefits



This is the way !



AFNeT Standards Days 2021 : 1 & 2 June 2021 <http://standardsdays.afnet.fr> 3

In total, more than 70 participants attended this conference online. LGM had the opportunity to highlight our expertise, both in the specifications related to support and in training engineering. We also took the opportunity to talk about our approach to Digital Continuity of Support. During the questions and answers session, we saw the growing interest in S6000T and in particular the need for dedicated support tools. All of this seems to be a good sign for our Digital Continuity of Support solution and LGM's ambition to confirm our position as the benchmark of expertise in the S-Series.

LGM thanks AFNet and Dassault Aviation.

You can watch this conference online via this [link](#).

Gilles BAUDOUX  
Training Business Manager  
Technical and Innovation department

# Agenda

From 13/10  
to 14/10

**LGM will be at the FED  
(Forum Entreprises Défense)  
on October 13 and 14, 2021**



<https://fed-mco-terre.com/>

The FED is a privileged space for meetings between professionals in the service of in-service support of land equipment. This has become the event you simply must not miss!



# Training



Connect to our [LGM ACADEMY](#) website to register for the next sessions

The 27/07

## SLI-12 - S5000F: Developing feedback

Know which data is exchanged between an operator and an industrial company to improve the system during its use:

- Presentation of the experience feedback and presentation of a use case of S5000F
- S5000F data exchange process
- Formalize with S5000F
- S5000F and ASD
- Presentation of the CDM (Common Data Model)

From 14/09  
to 16/09

## DOC-03 - DITA Training

Principles and implementation of the structured document standard DITA:

- Understand the concepts and data of the standard
- Be able to understand the specificities/advantages/disadvantages of DITA compared to other documentation standards (S1000D, DocBook...)
- Master the methodology for implementing the standard in a given business/ industrial context

You enjoyed this newsletter and you want to exchange information,  
share your experience or suggest topics for articles?

Contact us: [asdfactory@lgm.fr](mailto:asdfactory@lgm.fr)

